

- **Ideal replacement for paper recorder**
 - simple, cost-effective solution
- **Robust and convenient archive storage**
 - low cost, high reliability, SmartMedia and Compact Flash options
 - high capacity
- **Secure data recording**
 - internal Flash memory for 12 recording channels and logs
 - no battery back-up required
- **21 CFR Part II compliant data security**
 - extensive physical and electronic security features
- **Intuitive user interface**
 - dedicated tactile operator keys and Windows™-style menus
- **Unsurpassed environmental protection**
 - hosedown to IP66 and NEMA4X standards
- **Remote monitoring/access**
 - Ethernet communications, embedded web protocols/server



Simplicity without Compromise

SM1000

The SM1000 is a state-of-the-art solution to recording and data storage. It provides 12 recording channels and up to 12 universal analog inputs which can be viewed in a variety of display formats: chart, bargraph, digital indicator and process summary. Historical logs are provided for recording alarms, operator and system events and totalizer values.

The SM1000 has onboard Flash memory for secure storage of process data. A choice of removable storage devices are available; either SmartMedia or Compact Flash.

Application areas include:

- Water treatment plants
- Cold storage
- Stack gas monitoring
- Environmental monitoring
- Autoclaves
- Food, Dairy & Beverage processing
- Furnaces
- Heat treatment
- Pulp & Paper

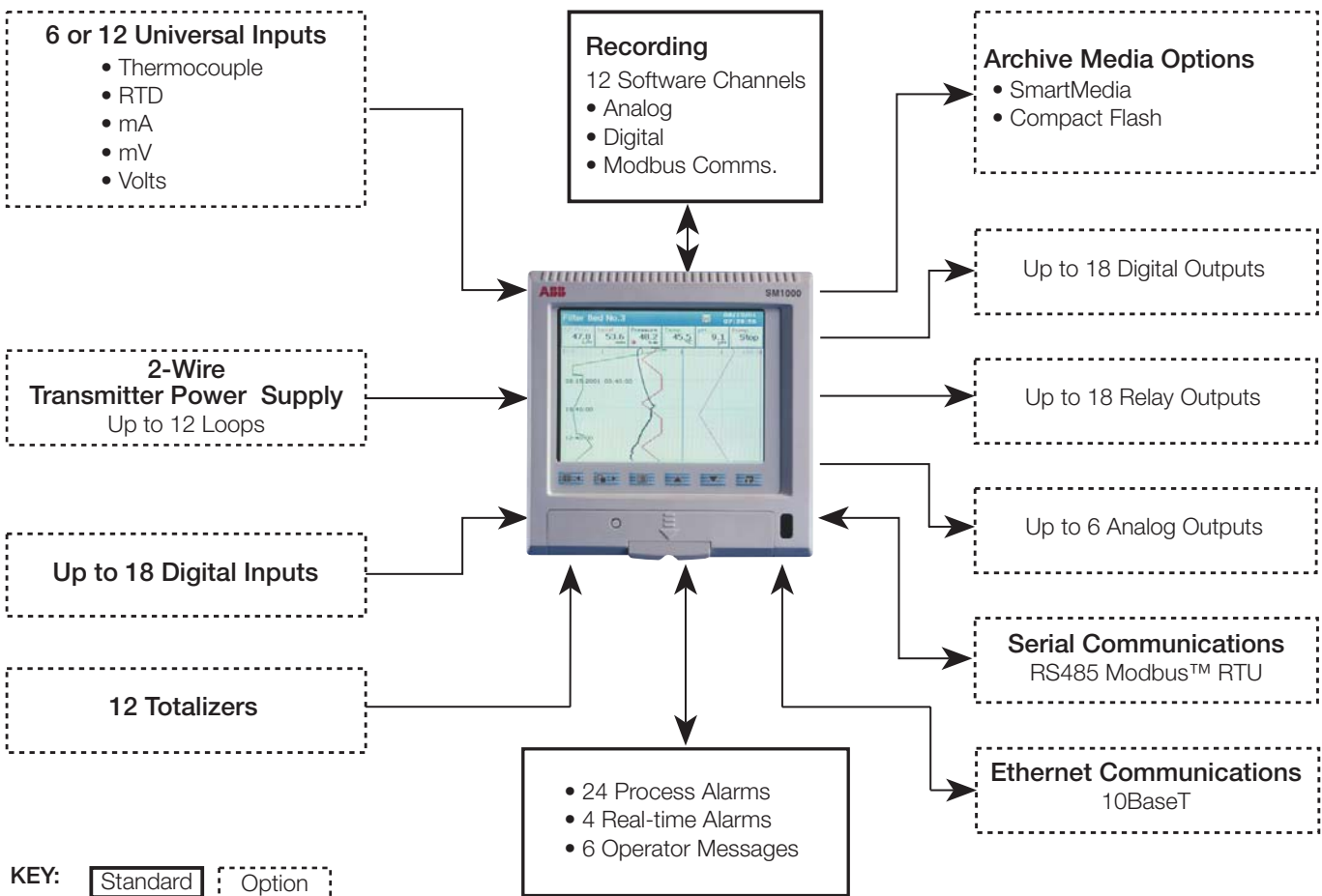

Simplicity of Use

- Six dedicated tactile keys are used for all aspects of operation and configuration of the SM1000.
- During everyday operation each key has a specific function ensuring simplicity of use.
- The use of a Windows-style pop-up menu and configuration screens ensures that the operation of the SM1000 is exceptionally easy and instantly familiar.

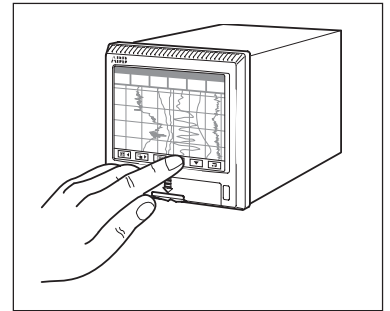

Guaranteed Data Integrity

- The use of Flash memory technology ensures that the SM1000 is not reliant on batteries to preserve stored data during a power failure.
- In the internal memory, data is stored in small blocks with each block containing a checksum to ensure the integrity of that data.
- Internal flash memory is provided for buffering of process data. At any time the complete memory can be reviewed in the Chart View of the SM1000. Once this memory is full it automatically wraps-around and overwrites the oldest data, ensuring that the latest process data is always captured.
- 12 recording channels are provided, as standard, which can be used to record any analog, digital or communications (via Modbus™) signal. Two sample rates can be pre-set in the configuration of the SM1000; a primary and a secondary (fast or slow). Automatic switching between these two sample rates allows detailed information to be stored under specific process conditions, for example, critical process states or alarm conditions. Through the use of pre-storage filters it is possible to record the average, max./min. or instantaneous value of any analog data.

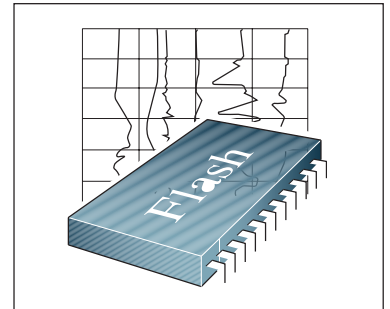

Industrial Standard, Robust, Archive Storage

- Either SmartMedia or Compact Flash memory cards can be used for archiving purposes. The solid state nature of these devices ensures that the SM1000 can truly operate in ambient temperatures up to 50 °C (122 °F), whereas traditional electro-mechanical floppy disk drives can operate only in temperatures up to 40 °C (104 °F).
- Every write to the archive storage media is verified to ensure the integrity of the data.
- Process data can be archived to the removable media in either of two configurable formats, comma separated variable or binary encoded. In addition to the analog/digital recording channels, the alarm event, totalizer (if fitted) and audit logs can also be archived to the removable media.
- Security of all process data stored to the memory card is always ensured. Files stored in comma separated variable format are attributed with an Encrypted Digital Signature and files stored in binary format are securely encoded with inbuilt integrity checks. Both formats of data storage are compliant with FDA standard 21 CFR Part II.
- A Media door lock is fitted as standard to prevent unauthorized access to the removable media.

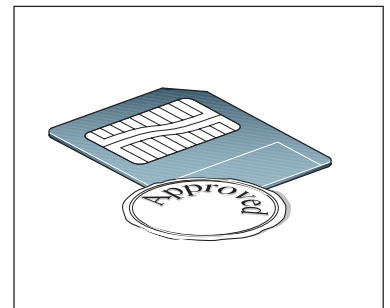

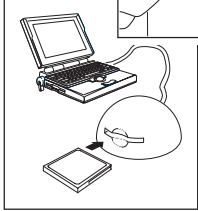
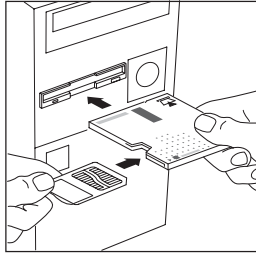

PC Interface for Archive Storage Media

Through the use of PC adapters for SmartMedia and Compact Flash, both options provide the advantages of very robust, solid-state storage with the convenience-of-use previously found only with floppy disks.

- A SmartMedia-to-floppy disk drive adapter enables SmartMedia cards to be read directly by the existing floppy disk drive on your computer.
- Archives stored on Compact Flash and SmartMedia can be accessed via a reader which plugs into the parallel or USB port of a desk/lap-top computer.

Low Cost of Ownership

The large capacity of the storage media used on the SM1000 ensures that the requirement for operator intervention to transfer the data to a PC on a regular basis is greatly reduced. Older floppy disk technology, used by many other manufacturers of graphical recorders, limits storage capability significantly, sometimes to levels below the ability of a traditional paper recorder.

See below for an example of how memory storage times vary depending on the media device. The example shows the recording duration for a 6-channel recorder with a sample time of 10 s configured to use binary archiving. Also included in the example is how these storage times compare with a traditional paper recorder.

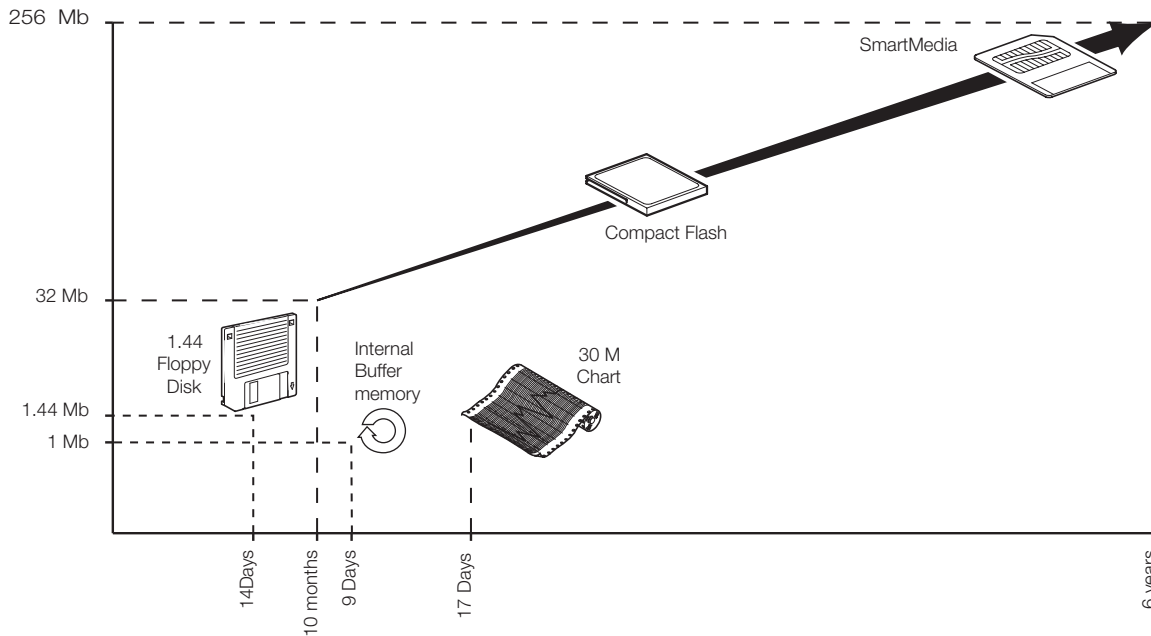

Unsurpassed Environmental Protection

Unique to this type of product, the SM1000 has unrivalled protection ratings of IP66 and NEMA4X and includes a fully-sealed, lockable media door. This enables the SM1000 to be installed, without additional protection, in applications that require frequent hosedown. With industrial standard noise emission and immunity protection, the SM1000 also operates effectively in high electrical-noise environments.

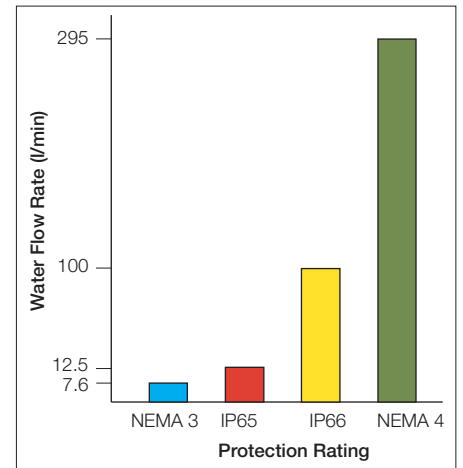

Intuitive User Interface

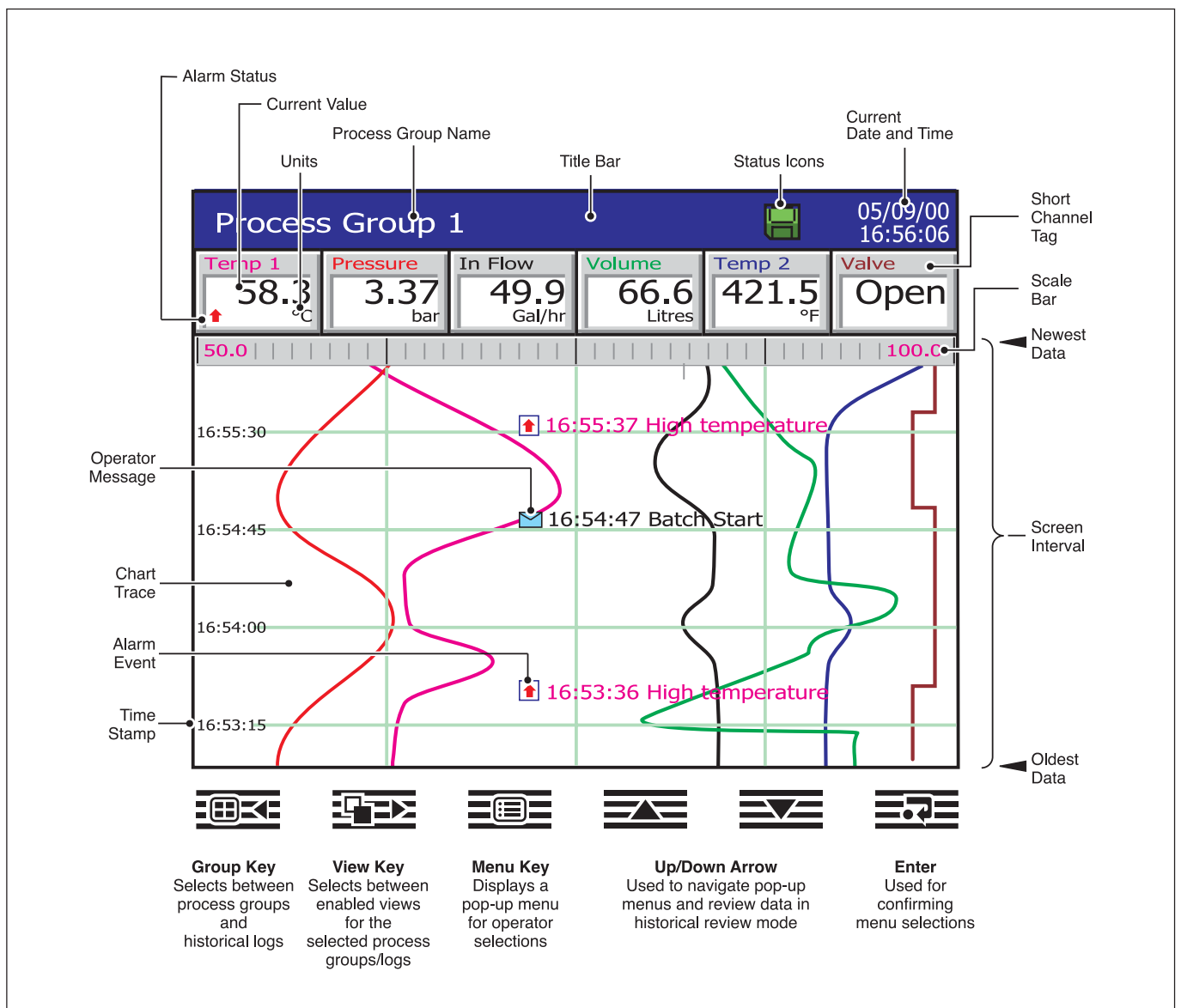

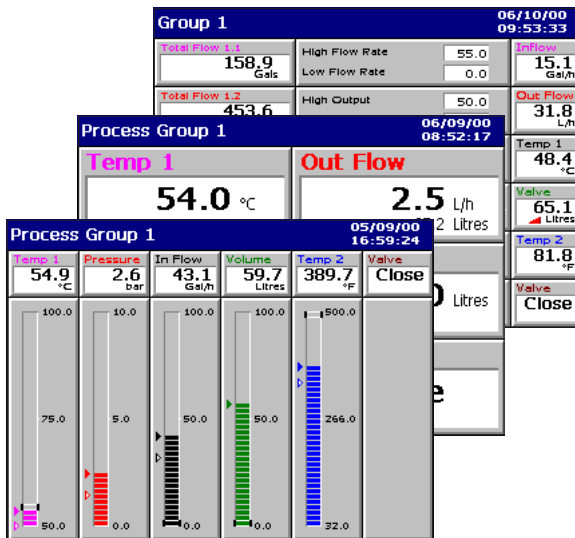

Operator Views

In addition to the standard chart view, a number of other operator views are available:

Process View

Provides an at-a-glance summary of each channel including alarm, totalizer and statistical (max./min.) information.

Digital Indicator View

Process value, engineering units, channel tag, associated totalizer (if fitted), and alarm status are all shown. Auto-sizing always ensures the clearest possible display.

Bargraph View

Horizontal or Vertical format which includes min./max. and alarm trip point markers.

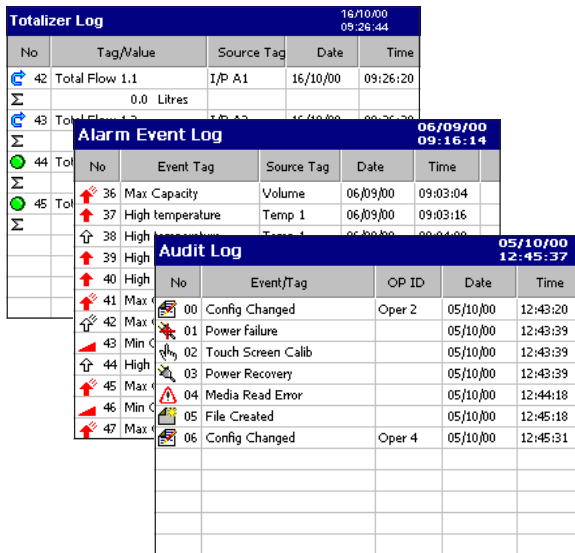

Historical Logs

Providing functions unavailable in paper based recorders, three historical logs ensure complete validity of the recorder and its data. Any or all of these logs can be exported to the removable media:

Alarm Event Log

Complete display of all acknowledged and unacknowledged alarms, alarm state changes and operator messages.

Audit Log

Displays time, date and ID stamped system data including configuration, calibration changes, system errors and operation actions. This provides comprehensive evidence of the integrity, validity and traceability of the SM1000 and its measured data.

Totalizer Log

Independent log intervals for each channel, enabling total, average, maximum and minimum readings to be time and date stamped.

Configuration

A simple Windows-style structure provides an exceptionally simple approach to the set up of the recorder. Text and numerical information is very quickly entered via an on-screen keyboard. Navigation of the configuration menus is performed via the cursor keys and the pop-up menu.

The configuration mode is protected via a user-specific password system. All configuration changes are logged in the Audit log complete with operator ID's.

It is also possible to configure the SM1000 with a Windows-based PC configuration package.



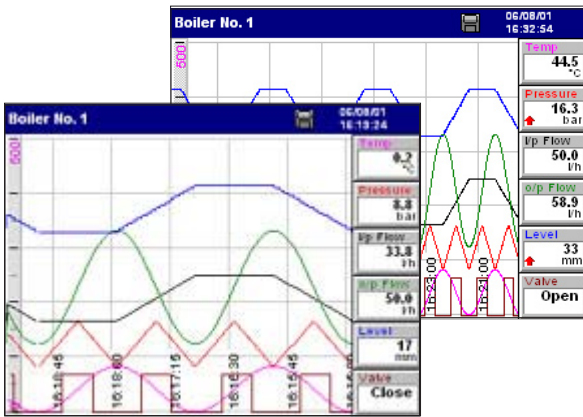

On-line Data Review

The SM1000 provides a number of unique features to provide a clear view of your process.

- The screen interval can be altered to display between 18s and 7 days of information, without it affecting the sample rate. This gives you the ability to 'zoom in' to a close-up view of the most current data or 'zoom out' and get the big picture.
- Individual traces can be removed temporarily from the screen to enable clear comparison of two or more channels.
- The instrument can easily review all historical data in the internal buffer memory at the touch of a button. During this time, recording of the process data to the internal memory remains unaffected.

Off-Line Review and Analysis

Using ABB's DataManager software, archived process data and historical logs recorded to a removable media card can be easily reviewed.

- Database management of data files provided by DataManager ensures simple, secure long-term storage and retrieval of historical data.
- The graphing capabilities provided by DataManager ensure easy interrogation of process data.
- The validity of all data files is always checked by DataManager during the storage and retrieval process ensuring maximum data integrity.

For further information on the capabilities of DataManager, refer to data sheet SS_DATMGR.

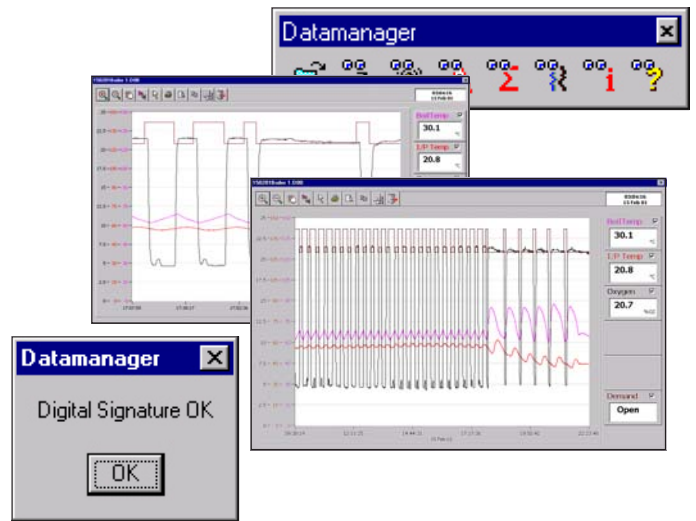

Batch Recording

A batch recording option enables simple recording and reviewing of batch processes. When a batch is started it is tagged with a unique batch number, operator identification and three user-definable description fields. All information is entered on-screen with a history function allowing quick entry of commonly repeated descriptions.

Using DataManager software batches can be simply and quickly traced for review using the unique batch number and description information entered at the time of recording. Additional functionality provides the ability to search and sort batch records for an entire production facility in many ways, including by product type, operator and time and date of processing.

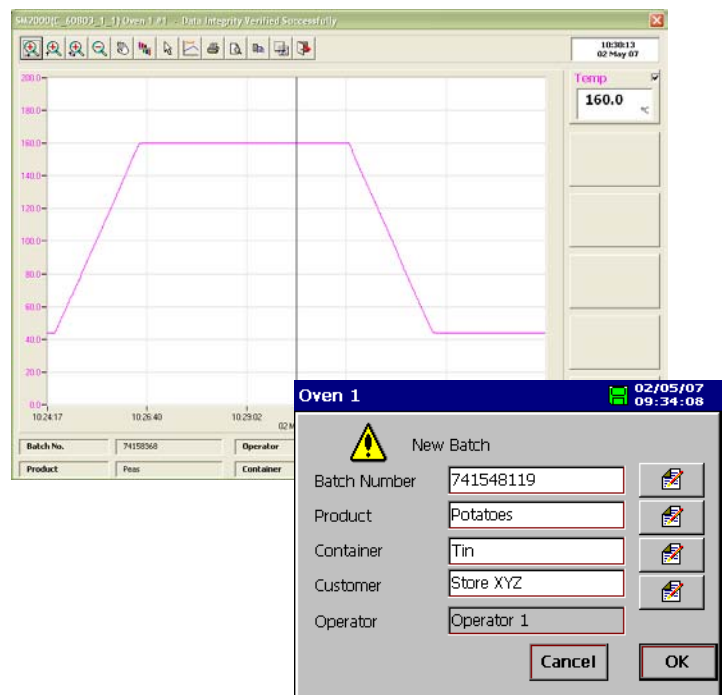

Ethernet Communications

The SM1000 can provide 10BaseT Ethernet communications via a standard RJ45 connector and uses industry-standard protocols TCP/IP, FTP and HTTP. The use of standard protocols enables easy connection into existing PC networks.

Data File Access via FTP (File Transfer Protocol)

The SM1000 features FTP server functionality. This functionality provides high-speed access via Ethernet to data archived by the recorder.

- Using a standard web-browser or other FTP clients, data files contained within the SM1000's internal memory and memory card can be accessed remotely and transferred to a PC or network drive.
- Four individual FTP users can be programmed into the SM1000. Access rights can be configured for each user specifying their access level.
- All FTP log-on activity is recorded in the audit log of the SM1000.
- Using ABB's data file transfer scheduler program, data files from multiple recorders can be automatically backed-up to a PC or network drive for long term storage ensuring the security of valuable process data and minimizing the operator intervention required.

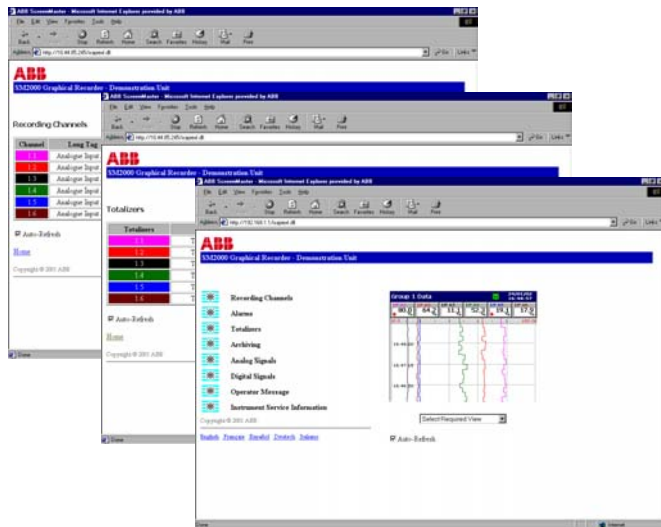
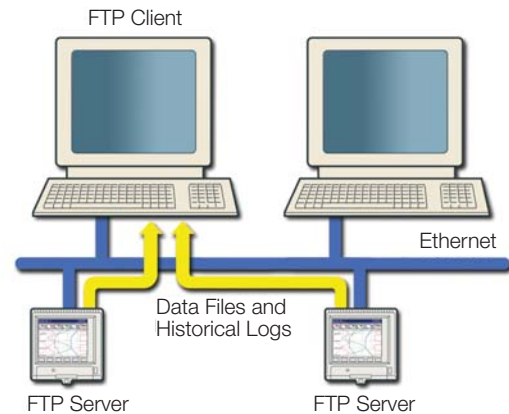

Embedded Web Server

Contained within the SM1000 is an embedded web-server allowing access to web pages created within the recorder. The use of HTTP (Hyper Text Transfer Protocol) enables standard web browsers to view these pages.

- Detailed with the web pages is the current display of the recorder, detailed information on process signals, alarm conditions, totalizer values and other key process information.
- The historical logs stored in the SM1000's internal buffer memory can be displayed in full from within the web pages.
- Operator messages can be entered via the web server allowing comments to be logged to the recorder.
- All of the information displayed on the web pages is regularly refreshed enabling them to be used as a process supervision tool.

On-line Demonstration

A demonstration of these features is available from an on-line recorder accessible via the internet. In the address bar of your web browser enter 'http://217.33.207.105'.

Remote Access/Monitoring

Ethernet communications can provide a link to recorders installed in remote locations. Via the use of a dial-up router an SM1000 can be installed in a remote location and accessed via a public telephone network when required.

Email Notification

Via the SM1000's inbuilt SMTP client the recorder is able to email notification of important events. Emails triggered from process alarms or other critical process events can be sent to multiple recipients. The recorder can also be programmed to email reports of the current process status at specific times during the day, the content of which can be tailored to suit your specific process needs.

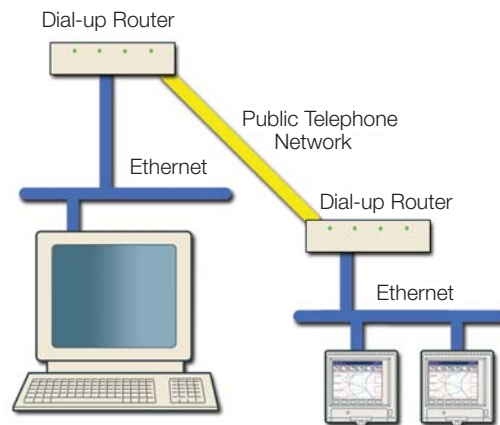

Specification

Operation and Configuration

Configuration

- Via tactile membrane switches on front panel or PC Configuration
- Multiple configuration files can be stored in internal (up to 16 files) or external memory (with removable media option fitted)

Configuration ports

- 3.5 mm jack socket for connection to RS232 port on a PC via an adapter

Display

- Color, passive matrix, liquid crystal display (LCD) with built-in backlight and contrast adjustment
- 125 mm (5 in.) diagonal display area, 76800 pixel display*

*Note. A small percentage of the display pixels may be either constantly active or inactive. Max. percentage of inoperative pixels <0.01 %.

Language

- English, German and French (Italian and Spanish pending)

Dedicated operator keys

- Group select/left cursor
- View select/right cursor
- Menu key
- Up/Increment key
- Down/Decrement key
- Enter key

Chart screen intervals

- Selectable from 18 s to 7 days

Chart divisions

- Programmable for up to 10 major and 10 minor divisions

Chart annotation

- Alarm and operator messages may be annotated on the chart
- Icons to identify the type of event, time of occurrence and tag are displayed

Security

Physical

- Standard door lock

Configuration security

- Password protection Access to configuration is allowed only after user has entered a password
- Internal switch protection Access to configuration is allowed only after hardware switch has been set. This switch is situated behind a tamper-evident seal

Logging security

- Configuration Can be configured for password protection or free access to logging levels

Basic type security

- 4 individual users with unique usernames and passwords

Advanced type security

- Number of users Up to 12
- Usernames Up to 20 characters. Usernames are unique (names cannot be repeated)
- Access privileges Logging access – Yes/No
Configuration access
None/Load file only/Limited/Full
- Passwords Up to 20 characters
A minimum required password length of 4 to 20 characters can be configured and a password expiry time can be applied to eliminate password ageing
- Password failure limit Configurable for 1 to 10 consecutive occasions or 'infinite'
A user is deactivated if a wrong password is entered repeatedly
- Deactivation of inactive users Can be disabled or configured for 7, 14, 30, 60, 90, 180 or 360 days of inactivity
Users are deactivated (by removal of access privileges) after a period of inactivity

Operator Views

Contents	Views Available			
	Chart	Bargraph	Digital Indicator	Process*
Instantaneous values/states	✓	✓	✓	✓
Units of measure	✓	✓	✓	✓
Short tags	✓	✓	✓	✓
Long tags				✓
Alarm status	✓	✓	✓	✓
Alarm trip markers		✓		
Alarm trip values				✓
Max./Min. markers		✓		
Analog bargraphs		✓		
Totalizer values & units of measure			✓*	✓
Totalizer tags				✓
Max., min. and average batch values				✓
Graphical view of historical data	✓			

*If Totalizer option is fitted and selected

...Specification

Standard Functionality

Operator Messages

Number

6

Trigger

Via front panel or digital signals

Recording in alarm/event log

Can be enabled or disabled on configuration

Process Alarms

Number

24 (2 per recording channel)

Types

High/Low process, latch & annunciator

Rate fast/slow

Tag

20-character tag for each alarm

Hysteresis

Programmable value and time hysteresis (1 to 9999 s)

Alarm enable

Allows alarm to be enabled/disabled via a digital input

Alarm log enable

Recording of alarm state changes in the alarm/event log can be enabled/disabled for each alarm

Acknowledgement

Via front panel or digital signals

Real-time Alarms

Number

4

Programmable

Day of the week, 1st of month, start and duration times

Custom Linearization

Number

2

Number of breakpoints

20 per linearizer

Recording to Internal Memory

Data Channels

Internal buffer memory

1 Mb Flash memory provides storage for 512 k samples
Oldest data is automatically overwritten by new data when memory is full

Data integrity checks

Checksum for each block of data samples

Independent process groups

2

No. of recording channels

12 (6 per group)

Sources

Analog inputs, Modbus™ inputs, any digital signal

Filters

Programmable for each channel to allow recording of: instantaneous values, average, max., min. and max. & min. value over sample time

Primary/secondary sample rates

Programmable from 0.1 s to 12 hours for each process group

Primary/secondary sample rate selection

Via any digital signal or from password protected menu

Recording start/stop control

Via any digital signal or from password protected menu

Recording Duration

Approximate duration calculated for continuous recording of 6 channels of analog data (for 12 channels divide by 2, for 3 channels multiply by 2 etc.)

Sample Rate	1 s	10 s	40 s	60 s	120 s	480 s
1 Mb Internal Flash buffer memory	23 hours	9 days	38 days	57 days	4 months	1 year

...Specification

Historical Logs

Types

Alarm/Event, Totalizer and Audit logs

No. of records in each historical log

Up to 200 in internal memory

Oldest data is automatically overwritten by new data when log is full

Historical Logs

Log Type	Alarm/Event Log		Totalizer Log*		Audit Log	
Information Recorded in Log	Log Entry Events					
	In Log	On Screen	In Log	On Screen	In Log	On Screen
	<ul style="list-style-type: none"> Alarm state changes Operator messages 		<ul style="list-style-type: none"> User defined logging intervals Totalizer stop/start, reset, wrap Power up/down 		<ul style="list-style-type: none"> Configuration/calibration changes System events Errors, operator actions 	
Date & time of event	✓	✓	✓	✓	✓	✓
Type of event	✓	✓	✓	✓	✓	✓
Tag	✓	✓	✓	✓		
Source tag	✓		✓			
Alarm trip value & units of measure	✓					
Alarm state	✓	✓				
Alarm acknowledgement state	✓	✓				
Operator ID	✓				✓	✓
Description					✓	✓
Batch total and units of measurement*			✓	✓		
Max., min. and average values plus units*			✓	✓		
Secure total			✓			

*If Totalizer option fitted and selected

Archiving to Removable Media

Removable storage media options

- None
- SmartMedia (3.3 V only)
- Compact Flash

Data that can be saved to removable media

- Recorded data for group 1 & 2 channels
- Alarm event log data
- Totalizer log data
- Audit log data
- Configuration

File structure

Configurable as either binary encoded or comma-separated

Filename

20-character tag, prefixed with date/time

Data verification

Carried out automatically on all writes to removable-media files

Card compatibility

ABB recorders comply with approved industry standards for memory cards and ABB has fully tested and recommend the use of SanDisk Standard Grade memory cards. Other brands may not be fully compatible with this device and therefore may not function correctly.

Card size

Cards up to 2 Gb capacity may be used

File Structure

	Binary	Comma-separated
File protection	Secure binary format with data integrity checks	Encrypted digital signature
New file generation interval	Automatic	Programmable for automatic file generation every hour, day or month
Archive sample rates	Programmable from 0.1 s to 12 hours for each process group*	Programmable from 1 s to 12 hours for each process group

*For sample rates faster than 1 s the performance of the analog input card must be considered. For more information on this please refer to page 14 of this data sheet. Further information is also available from your local ABB representative.

Recording Duration

Approximate duration calculated for continuous recording of 6 channels of analog data (for 12 channels divide by 2, for 3 channels multiply by 2 etc.)

Binary Encoded File

Sample Rate	1 s	10 s	40 s	60 s	120 s	480 s
128 Mb SmartMedia/Compact Flash	4 months	40 months	13 years	20 years	39 years	159 years
256 Mb SmartMedia/Compact Flash	8 months	80 months	26 years	39 years	79 years	319 years
512 Mb SmartMedia/Compact Flash	16 months	161 months	53 years	79 years	159 years	635 years
1 Gb SmartMedia/Compact Flash	31 months	26 years	103 years	155 years	311 years	1246 years

Comma-separated File

Sample Rate	1 s	10 s	40 s	60 s	120 s	480 s
128 Mb SmartMedia/Compact Flash	0.9 months	8 months	35 months	53 months	8 years	35 years
256 Mb SmartMedia/Compact Flash	2 months	17 months	71 months	8 years	17 years	70 years
512 Mb SmartMedia/Compact Flash	4 months	35 months	11 years	17 years	35 years	140 years
1 Gb SmartMedia/Compact Flash	7 months	5 years	22 years	34 years	68 years	275 years

...Specification

Analog Input Modules

General

Number of inputs

6 per board, max. of 12 inputs

Input types

mA, mV, voltage, resistance, THC, RTD

Thermocouple types

B, E, J, K, L, N, R, S, T

Resistance thermometer

PT100

Other linearizations

\sqrt{x} , $x^{3/2}$, $x^{5/2}$, custom linearization

Digital filter

Programmable 0 to 60s

Display range

-999 to 9999

Common mode noise rejection

>120 dB at 50/60 Hz with 300 Ω imbalance resistance

Normal (series) mode noise rejection

>60 dB at 50/60 Hz

CJC rejection ratio

0.05 $^{\circ}\text{C}/^{\circ}\text{C}$

Sensor break protection

Programmable as upscale or downscale

Temperature stability

0.02 $\%/^{\circ}\text{C}$ or 2 $\mu\text{V}/^{\circ}\text{C}$

Long term drift

<0.2 % of reading of 20 μV annually

Input impedance

>10 M Ω (millivolts inputs)

500 k Ω (voltage inputs) externally mounted divider

10 Ω (mA inputs) externally mounted on terminals*

*Hart transmitters require a minimum 250 Ω loop impedance. A voltage divider board fitted with a 250 Ω shunt resistor (GR2000/0377) can be used to meet this requirement. In such cases the input should be programmed for 1 to 5 V.

Standard/High Specification Analog Input Modules

Linear Inputs	Standard Analog Input	High Specification Analog Input	Accuracy (% of reading)
Millivolts	0 to 2000 mV	-1000 to +1000 mV	0.1 % or $\pm 10 \mu\text{V}$
Milliamps	0 to 50 mA	-100 to +100 mA	0.2 % or $\pm 2 \mu\text{A}$
Volts	0 to +20 V*	-50 to +50 V*	0.2 % or $\pm 10 \text{mV}$
Resistance Ω	0 to 5000 Ω	0 to 2000 Ω	0.2 % or $\pm 0.08 \Omega$
Sample Interval	100 ms per sample (2 modules are processed in parallel) gives worst case update times as follows: 600 ms for 6 or 12 channels – mV, mA, voltage 800 ms for 6 or 12 channels – THC 1100 ms for 6 or 12 channels – resistance, RTD	100 ms per sample (2 modules are processed in parallel) gives worst case update times as follows: 100 ms for 6 or 12 channels – all input types	
Input Isolation	35 V DC channel-to-channel	500 V DC channel-to-channel	
Isolation from Rest of Instrument	Galvanically isolated to 500 V DC	Galvanically isolated to 500 V DC	

* Requires external voltage divider board Part No. GR2000/0375

Analog Input Types

Thermocouple	Maximum Range $^{\circ}\text{C}$	Maximum Range $^{\circ}\text{F}$	Accuracy (% of reading)
B	-18 to 1800	0 to 3270	0.1 % or $\pm 2 \text{ }^{\circ}\text{C}$ (3.6 $^{\circ}\text{F}$) (above 200 $^{\circ}\text{C}$ [392 $^{\circ}\text{F}$])
E	-100 to 900	-140 to 1650	0.1 % or $\pm 0.5 \text{ }^{\circ}\text{C}$ (0.9 $^{\circ}\text{F}$)
J	-100 to 900	-140 to 1650	0.1 % or $\pm 0.5 \text{ }^{\circ}\text{C}$ (0.9 $^{\circ}\text{F}$)
K	-100 to 1300	-140 to 2350	0.1 % or $\pm 0.5 \text{ }^{\circ}\text{C}$ (0.9 $^{\circ}\text{F}$)
L	-100 to 900	-140 to 1650	0.1 % or $\pm 1.5 \text{ }^{\circ}\text{C}$ (2.7 $^{\circ}\text{F}$)
N	-200 to 1300	-325 to 2350	0.1 % or $\pm 0.5 \text{ }^{\circ}\text{C}$ (0.9 $^{\circ}\text{F}$)
R	-18 to 1700	0 to 3000	0.1 % or $\pm 1 \text{ }^{\circ}\text{C}$ (1.8 $^{\circ}\text{F}$) (above 300 $^{\circ}\text{C}$ [540 $^{\circ}\text{F}$])
S	-18 to 1700	0 to 3000	0.1 % or $\pm 1 \text{ }^{\circ}\text{C}$ (1.8 $^{\circ}\text{F}$) (above 200 $^{\circ}\text{C}$ [392 $^{\circ}\text{F}$])
T	-250 to 300	-400 to 550	0.1 % or $\pm 0.5 \text{ }^{\circ}\text{C}$ (0.9 $^{\circ}\text{F}$)
RTD	Maximum Range $^{\circ}\text{C}$	Maximum Range $^{\circ}\text{F}$	Accuracy (% of reading)
PT100	-200 to 600	-325 to 1100	0.1 % or $\pm 0.5 \text{ }^{\circ}\text{C}$ (0.9 $^{\circ}\text{F}$)

Modules

3- or 6-relay Output Modules

Number of relays

3 or 6 per module

Type and rating

Relay type single-pole changeover

Voltage 250 V AC 30 V DC

Current 5 A AC 5 A DC

Loading (non-inductive) 1250 VA 150 W

Note. The total load for all relays within the instrument must not exceed 36 A.

Hybrid Module

Digital I/O

Number 6 inputs and 6 outputs per card

Type Volt-free switching inputs

Polarity Negative i.e. closed switch contact or 0 V = active signal

Digital input min. pulse 100 ms

Digital output voltage 5 V

Isolation 500 V DC from any other I/O

Analog output

Number 2 isolated

Configurable current range 0 to 20 mA

Max. load 750 Ω

Isolation 500 V DC from any other I/O

Accuracy 0.25 %

2-wire Transmitter Power Supply Module

Number

2 isolated supplies per module

Voltage

24 V DC nominal

Drive

45 mA per supply, i.e. each module can drive $2 \times 2 = 4$ loops

Ethernet Module

Physical medium

10BaseT

Protocols

TCP/IP, ARP, ICMP, FTP (server), HTTP

FTP server functions

Directory selection & listing

File upload/download

Four, independently configurable users with full or read-only access

Web server functions

Operator screen monitoring/selection. Remote monitoring of recording channels, analog/digital signals, alarms, totalizers and archiving.

RS485 Serial Communications Module

Number of ports

1 as option

Connections

RS485, 2- or 4-wire

Protocol

Modbus™ RTU slave

Totalizer (optional)

Number

12 (1 per recording channel) 10-digit totals

Type

Analog or digital, batch and secure totals

Statistical calculations

Average, maximum, minimum (for analog signals)

EMC

Emissions & immunity

Meets requirements of:

EN50081-2

EN50082-2

EN61326 for an industrial environment

...Specification

Electrical

Power supply

85 V min. to 265 V max. AC 50/60 Hz
24 V DC \pm 4 V (optional)

Power consumption

35 VA max.

Power interruption protection

No effect for interrupts of up to 20 ms

Safety

General safety

EN61010-1
Overvoltage Class III on mains, Class II on inputs and outputs
Pollution category 2

Isolation

500 V DC to earth (ground)

Environmental

Operating temperature range

0 to 50 °C (32 to 122 °F) with SmartMedia/Compact Flash

Operating humidity range

5 to 95 %RH (non-condensing)

Storage temperature range

-10 to 60 °C (14 to 140 °F)

Front panel sealing

IP66 and NEMA4X

Rear panel sealing

IP40 (with rear cover)
IP20 (without rear cover)

Vibration

Conforms to EN60068-2

Physical

Size

144 mm (5.67 in.) x 144 mm (5.67 in.) x
195 mm (7.68 in.) depth behind panel

Weight

2.6 kg (5.6 lb) approx. (unpacked)

Panel cutout

138 mm (5.43 in.) x 138 mm (5.43 in.)

Case material

10 % glass-filled polycarbonate

Display housing material

40 % glass-filled polycarbonate

Membrane switch

Polyester, metal dome, tactile feel

Electrical Connections

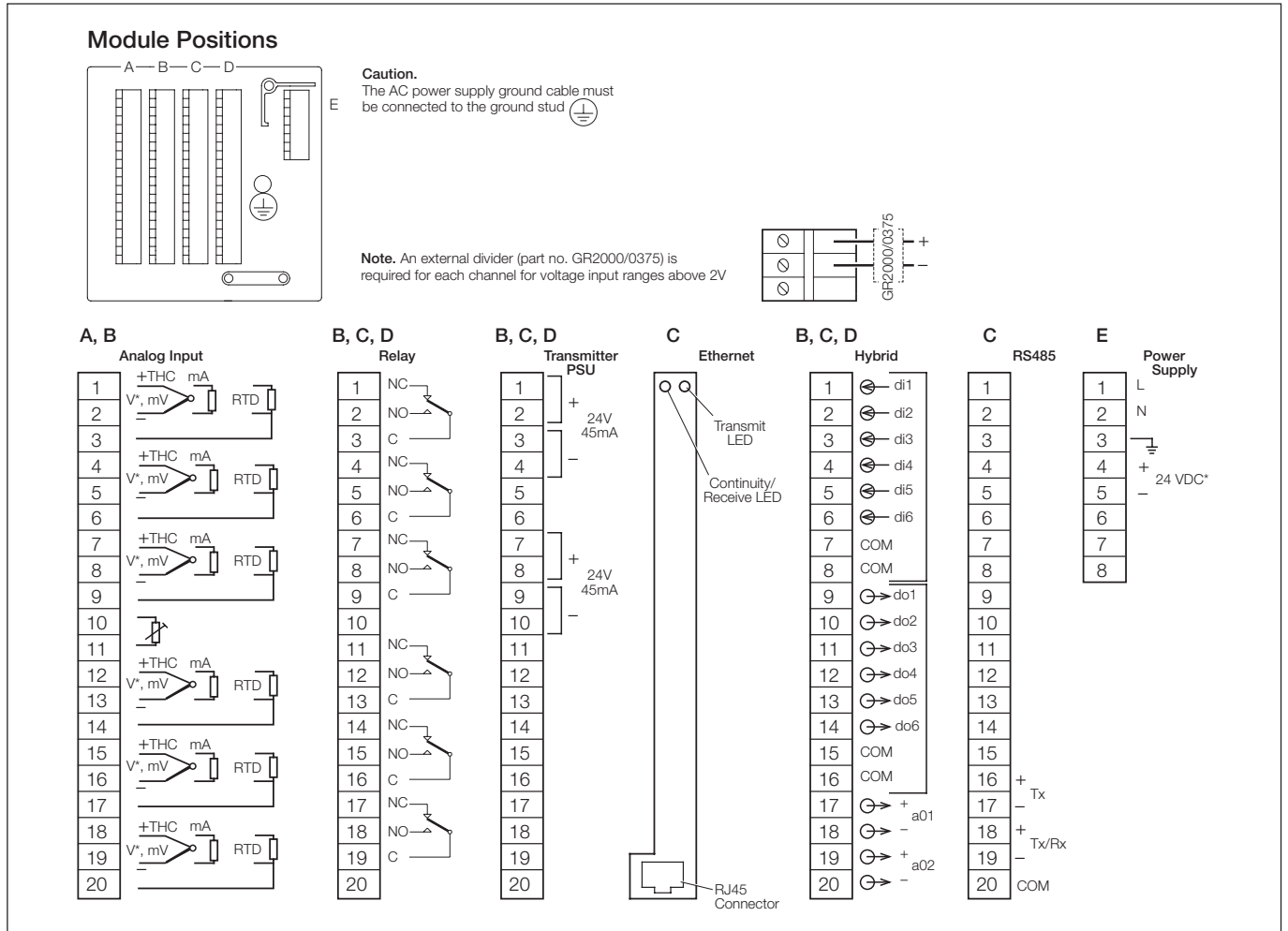

*Note. 24V DC instrument power supply must be specified when ordering.

Overall Dimensions

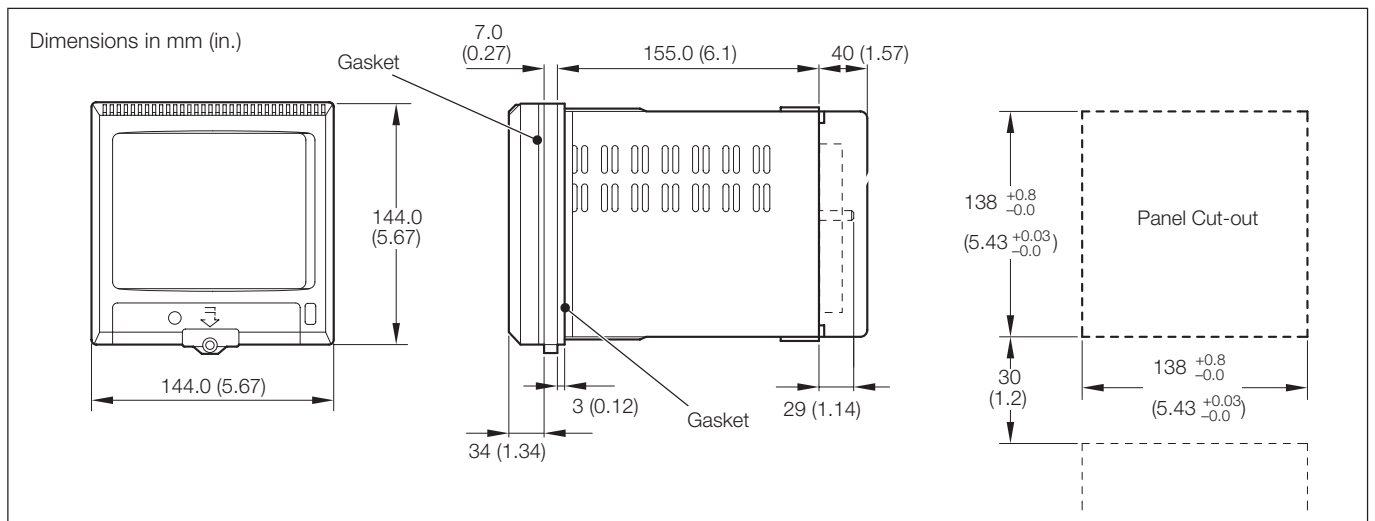

Ordering Information

SM1000 Videographic Recorder	SM10	XXX/	X	X	X/	X	X	X	X/	X	X/	XXX
Universal Analog Inputs												
None		00S										
6 – standard specification		06S										
12 – standard specification		12S										
6 – high specification		06H										
12 – high specification		12H										
Build Option												
Standard			B									
cCSAus*			C									
UL*			U									
Archive Media												
None – (internal flash memory only)					0							
SmartMedia drive					1							
Compact flash drive					2							
Software Option												
None						0						
Totalizers						2						
Batch recording						4						
Batch recording & Totalizers						5						
Option Modules												
Position A	Reserved for analog inputs									0		
Position B	Reserved for analog inputs if 12 inputs are specified									0		
	3 relays									3		
	6 relays									6		
	Hybrid – 6 digital inputs, 6 digital outputs, 2 analog outputs									H		
	2-wire transmitter power supply									T		
Position C	None									0		
	3 relays									3		
	6 relays									6		
	Ethernet (10BaseT) communications									E		
	RS485 Modbus serial communications									S		
	Hybrid – 6 digital inputs, 6 digital outputs, 2 analog outputs									H		
	2-wire transmitter power supply									T		
Position D	None									0		
	3 relays									3		
	6 relays									6		
	Hybrid – 6 digital inputs, 6 digital outputs, 2 analog outputs									H		
	2-wire transmitter power supply									T		
Case												
Without terminal compartment												2
With terminal compartment												3
Power Supply												
85 V min. to 265 V max. AC												2
24 V DC												3
Special Features												
Standard												STD
Custom configuration												CUS

* Not available in conjunction with High Specification inputs or 24 V DC power supply

Standard Accessories

Included with each recorder:

Panel-mounting Clamps
Media-door Lock keys
Shunt Resistors (1 per anaolog input)
Compact Flash Card (only with Compact Flash Memory Card option)

Optional Accessories

Part No. Description

Compact Flash Cards

B12156 Compact Flash Card (512 Mb)
B12567 Compact Flash Card (1 Gb)
B12568 Compact Flash Card (2 Gb)

Card Readers

B12028 Compact Flash Reader (USB Interface)*

Other

GR2000/0375 Voltage divider board (2 to 20 V) – per voltage input channel
GR2000/0377 Voltage divider board fitted with 250 Ω shunt resistor
SW/DATMGR DataManager Software

* Compatible with Windows 98/98se, ME, 2000 & XP

Licensing, Trademarks and Copyrights

Modbus™ is a trademark of Modicon, Inc.
Windows™ is a trademark of the Microsoft Corp.

ABB has Sales & Customer Support
expertise in over 100 countries worldwide

www.abb.com

The Company's policy is one of continuous product
improvement and the right is reserved to modify the
information contained herein without notice.

Printed in UK (11.07)

© ABB 2007



ABB Limited
Howard Road, St Neots
Cambridgeshire
PE19 8EU
UK
Tel: +44 (0)1480 475321
Fax: +44 (0)1480 217948

ABB Inc.
125 E. County Line Road
Warminster, PA 18974
USA
Tel: +1 215 674 6000
Fax: +1 215 674 7183